

SCUBAPRO

Repair Guide

X650

Second Stage



X650











USE THIS GUIDE AS A REFERENCE WHEN SERVICING THE X650
SECOND STAGE

©2003 SCUBAPRO





important note: The following information is not designed to be a complete training guide for servicing the listed SCUBAPRO regulators. All SCUBAPRO technicians are required to attend an annual service training program to insure safe handling and servicing of SCUBAPRO products. All SCUBAPRO technicians must be employed by an authorized SCUBAPRO facility.

**TOOLS NEEDED FOR REPAIR
OF X650**





Quantity	Part Number	Description	
1	43.650.220	X-650 Lever Tool	
1 set	10.102.100 (Peter Built)	Brass o'ring picks	
1 tube	41.047.000	Christo-Lube	
1	47.010.000	Counter Mat	
1	41.496.101	Lubricant syringe	
1	43.040.000 (Scubapro)	Universal Tool	
1		Jeweler's screwdriver (3mm)	
1		Philip's Screwdriver	
1	20.500.200 (Peter Built)	Pneumatic Adjusting tool	
1	18.300.500 (Peter Built)	Blow Gun/Air Nozzle	

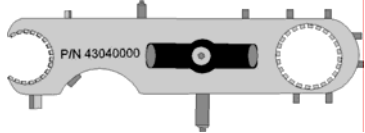
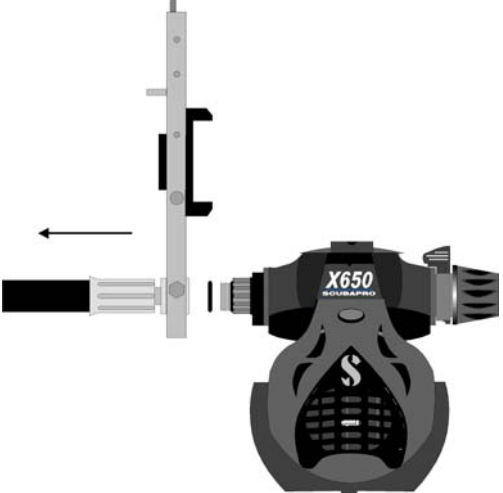

ICON LEGEND

	Inspect carefully, replace if needed
	Lubricate properly
	Replace annually
	Dynamic o'ring, replace annually and lubricate properly
	No tools needed for this step

SCUBAPRO X650 SECOND STAGE

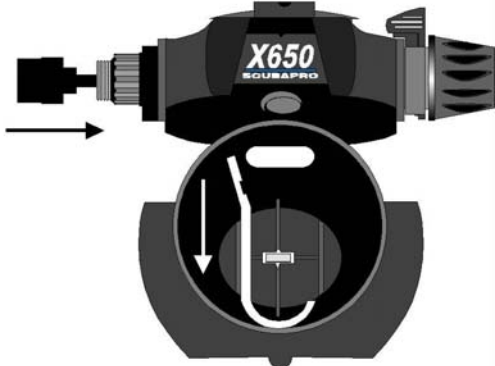

	
<p>Remove hose from the second stage.</p> <p>Remove the hose o'rings.</p>	
	
<p>With the small Philips screwdriver, loosen and remove the 2 screws from the top of the case.</p> <p>Remove the o'ring.</p>	<p>This step performed only as needed</p> 

SCUBAPRO X650 SECOND STAGE

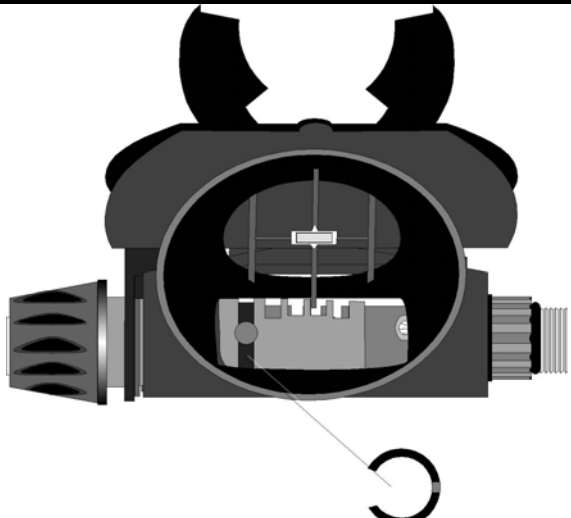
		<p>No tools needed this step</p>
<p>Remove the front cover. Loosen and remove the diaphragm cover ring, frictionless washer and diaphragm.</p>		
		
<p>Insert the X-650 tool as shown. Apply gentle pressure to the poppet and remove the lever by gently pulling downward.</p>		

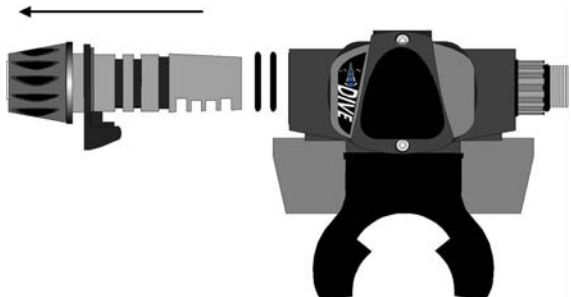
	
<p>Turn the housing upside down as shown and view the dive switch assembly through the front cover opening.</p> <p>Remove the stop clip using the small screwdriver or o'ring pick.</p>	

		<p>No tools needed this step</p>
<p>Remove the adjustment assembly and dive switch from the case.</p> <p>Remove the two o'rings.</p>		

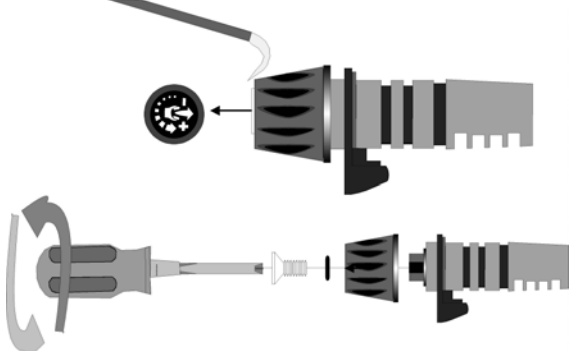

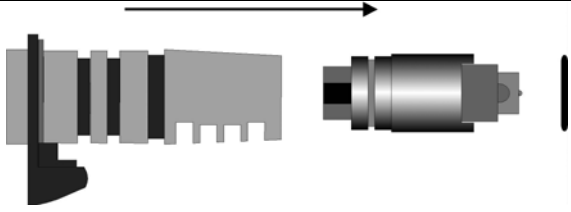
		
<p>Remove the decal from the adjustment knob as shown.</p> <p>Loosen the Philips screw and remove the o'ring from the adjustment knob.</p>		

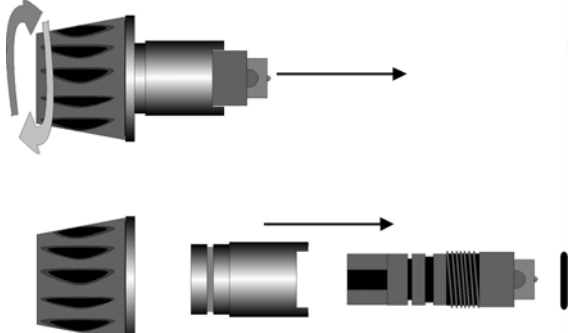

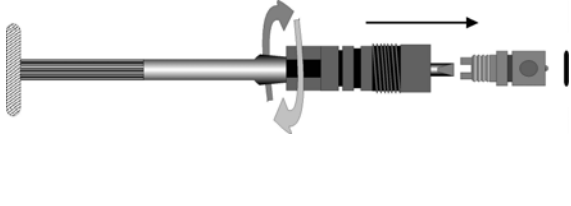
		<p>No tools needed this step</p>
<p>Push the adjustment components out of the dive switch as shown.</p> <p>Remove the o’ring.</p>		

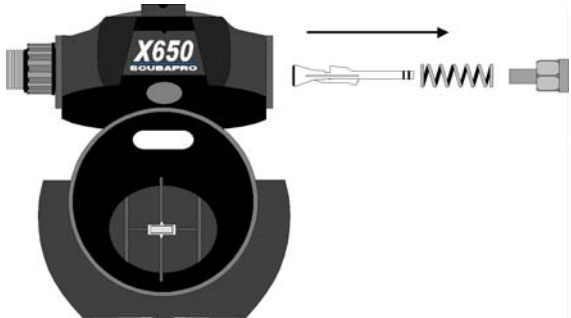
		<p>No tools needed this step</p>
<p>To remove the knob stem, use the knob.</p> <p>Hold the sleeve and screw the knob clockwise.</p> <p>Remove the o’ring.</p>		

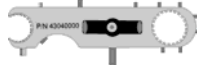
		
<p>Use the small screwdriver to thread the adjustment screw clockwise. Carefully remove the screw.</p> <p>Remove the o’ring as shown.</p>		



<p>Remove the balance chamber, spring, and poppet as shown.</p>		<p>No tools needed this step</p>
		

<p>Remove the jam nut using the universal tool.</p> <p>Remove the o'ring.</p> <p>Remove the air barrel from the case as shown</p>		
		

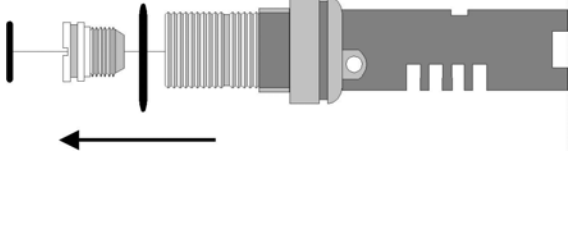
<p>Remove the o'rings and seat from the poppet body. These are replaced with new components.</p>		<p>No tools needed this step</p>
		

<p>Remove the adjustable orifice and push it out carefully as shown.</p> <p>Remove the o'ring from the adjustable orifice and from the air barrel.</p>		
		

SCUBAPRO X650 SECOND STAGE

	
<p>To remove the exhaust valve cover, use the small screwdriver to push the stainless pin away.</p> <p>NOTE: The exhaust valve will seldom need to be replaced. Careful inspection is usually all that is necessary. If the valve is removed during service, it may be damaged during the process, <u>requiring</u> replacement.</p>	<p>This Step Is Only Performed As Needed</p> 

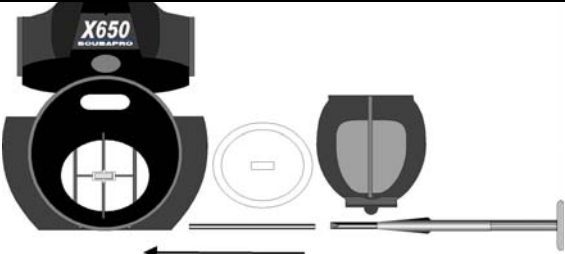
	
<p>To replace the exhaust valve cover, use the small screwdriver to push the stainless pin back into place.</p> <p>NOTE: The exhaust valve will seldom need to be replaced. Careful inspection is usually all that is necessary. If the valve is removed during service, it may be damaged during the process, <u>requiring</u> replacement.</p>	<p>This Step Is Only Performed As Needed</p> 

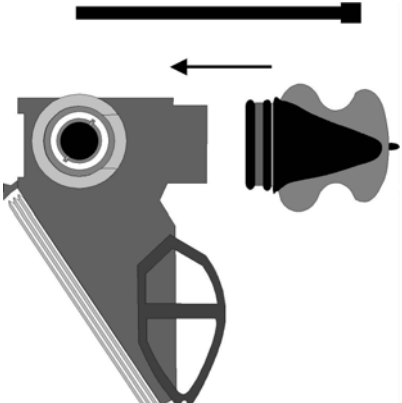
		<p>No tools needed this step</p>
<p>Inspect and replace the mouthpiece if needed.</p>	<p>Perform this step only if needed</p> 	

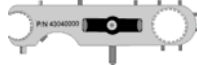
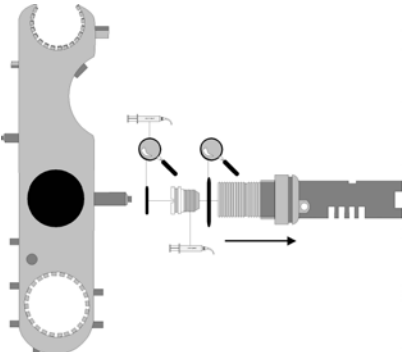

SCUBAPRO X650 SECOND STAGE

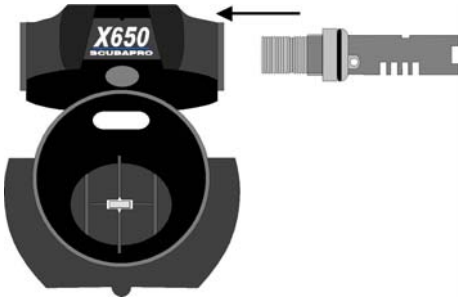
	
<p>Lubricate and place the o’ring on the adjustable orifice. Lightly lubricate the threads.</p> <p>Use the Universal Tool to thread in the adjustable orifice 3 or 4 turns.</p> <p>Place the o’ring onto the air barrel. NOTE: Lubrication of the air barrel o’ring is not necessary.</p>	

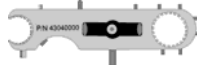
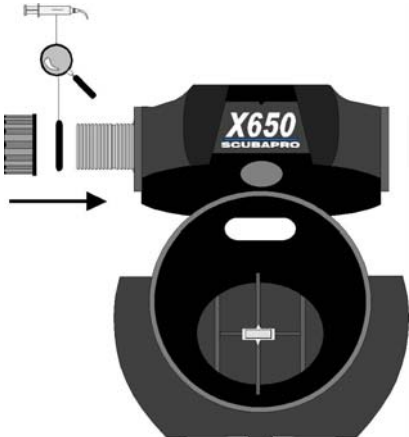
		<p>No tools needed this step</p>
<p>Insert the air barrel into the case as shown, being certain that the aspirator holes are facing the mouthpiece opening.</p> <p>Push firmly into position.</p>		



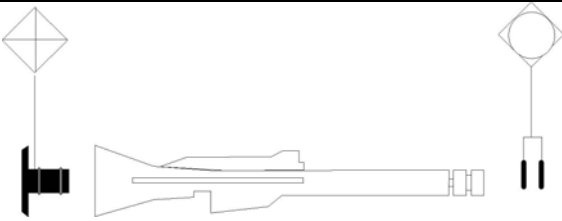

	
<p>Lightly lubricate the air barrel threads before fitting the o’ring into place.</p> <p>Thread the jam nut onto the air barrel threads and tighten with Universal Tool.</p> <p>Fit the second o’ring next to the jam nut as shown.</p>	

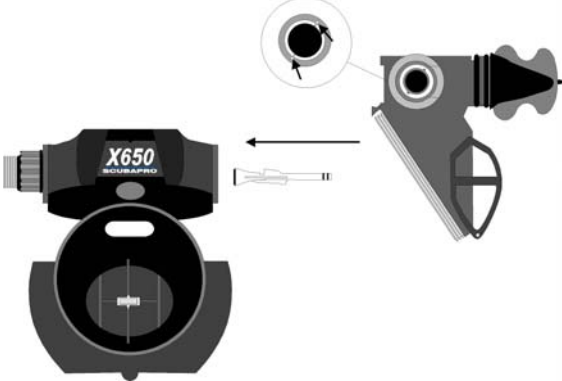
SCUBAPRO X650 SECOND STAGE

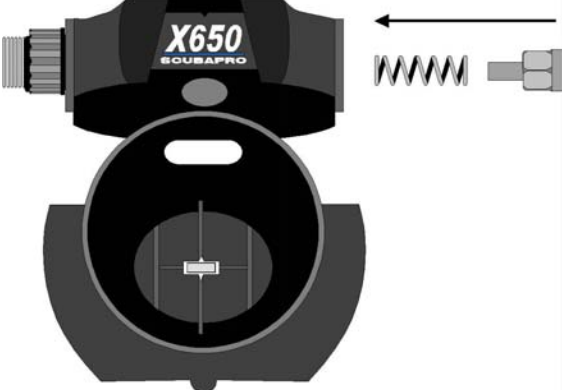

		
<p>Prepare the poppet by replacing the seat and replacing the dynamic o’rings.</p>		

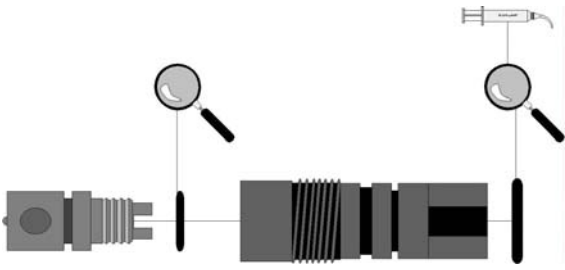
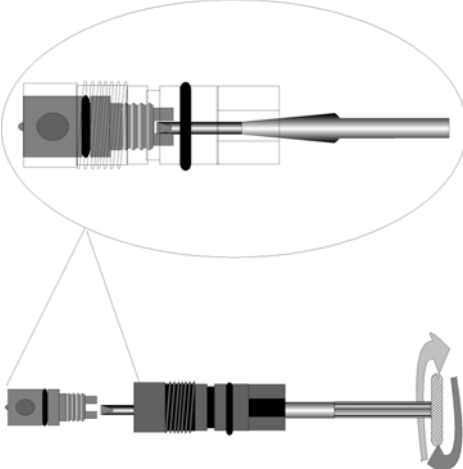
		<p>No tools needed this step</p>
<p>Hold the poppet shaft and guide the poppet “wings” into the grooves of the air barrel by positioning the lever tab toward the mouthpiece tube.</p> <p>CAUTION: If the poppet is not installed properly it will not move freely inside the air barrel.</p>		

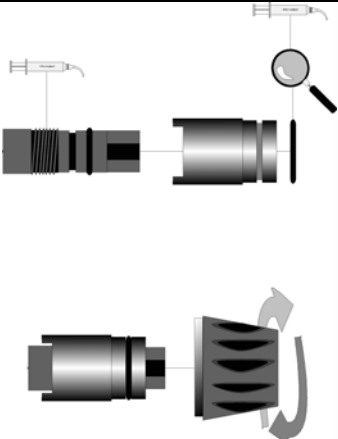
		<p>No tools needed this step</p>
<p>Install the spring and the balance chamber as shown.</p>		

		
<p>Install the o’ring on the fine adjustment screw and the knob stem as shown.</p> <p>NOTE: Do not lubricate the inner thread or o’ring.</p>		
<p>Thread the fine adjustment screw into the knob stem. Turn counterclockwise using the 3mm jeweler’s screwdriver until the fine adjustment screw is flush with the bottom of the knob stem.</p> <p>Slide the external knob on the stem and turn counterclockwise to “pull” the mechanism into the knob assembly.</p>		
		
<p>Inspect and lubricate the sleeve o’ring.</p> <p>Lightly lubricate the knob stem threads.</p> <p>Thread the knob stem into the sleeve.</p> <p>Use the adjustment knob to turn the knob stem counterclockwise until it is snug against the top of the sleeve.</p>		

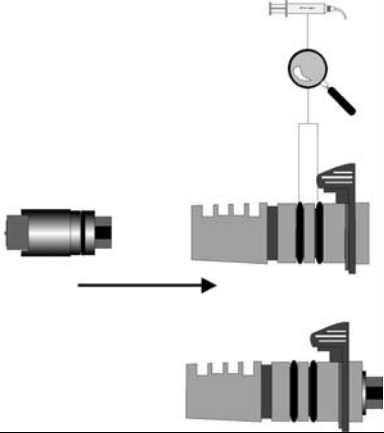

SCUBAPRO X650 SECOND STAGE

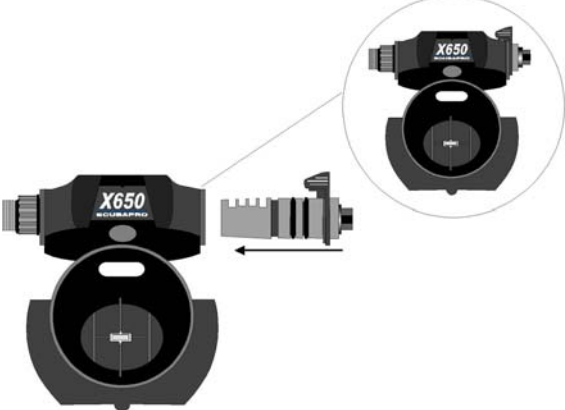

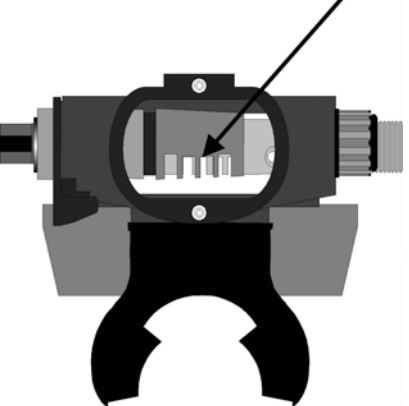
		
<p>Inspect, lubricate and install the o’rings on the dive switch.</p> <p>Install the adjustment assembly into the dive switch as shown.</p>		

		<p>No tools needed this step</p>
<p>Install the dive switch into the housing as shown.</p>		

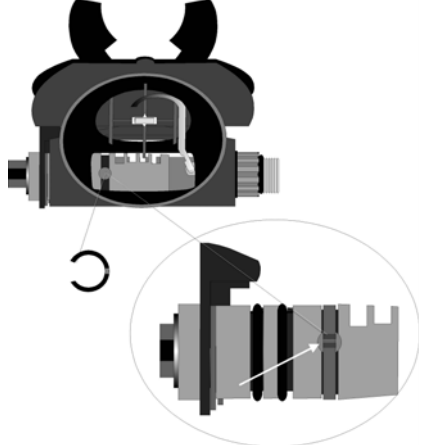
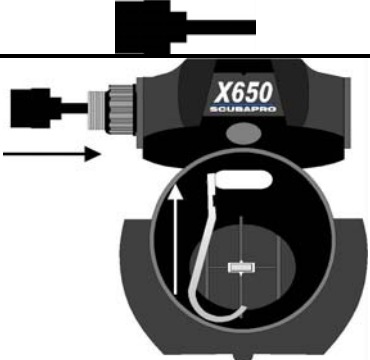
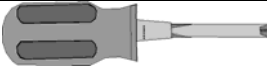

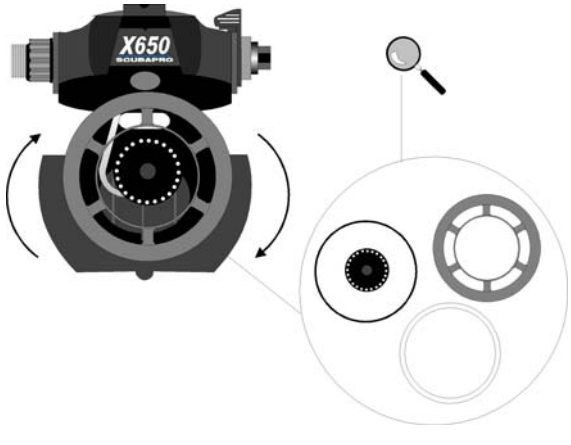

		<p>No tools needed this step</p>
<p>Properly installed the dive switch lever fits into a groove on the casing.</p> <p>If the top cover has been removed (only done as required) the sleeve tabs can be seen engaged with the air barrel slots.</p>		

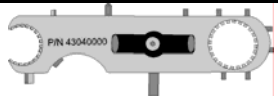
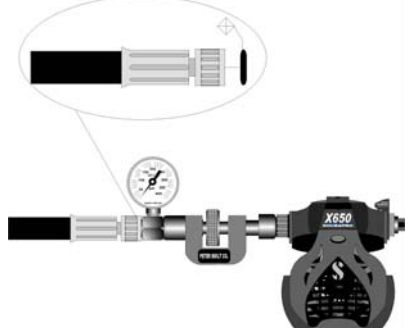
SCUBAPRO X650 SECOND STAGE

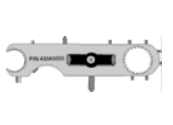

		<p>No tools needed this step</p>
<p>The stop clip groove should be now visible when case is turned upside down.</p> <p>Install the stop clip. The “nipples” on the stop clip should be aligned with the round depression in the dive switch.</p>		
<p>Use the X-650 tool to install the lever as shown and engage the poppet.</p> <p>NOTE: Apply pressure to the poppet to determine if the poppet moves freely and is installed properly.</p>		
		
<p>If the case plug was removed, inspect and lubricate the top case plug o’ring. Install as shown.</p> <p>Lubricate the first two or three threads of the screws and thread into the case and plug.</p> <p>CAUTION: Do not over-tighten screws.</p>	<p>This step performed only as needed</p> 	

		<p>No tools needed this step</p>
<p>Inspect, clean and install the diaphragm.</p> <p>Install the frictionless washer and cover.</p>		
		<p>No tools needed this step</p>
<p>Install the diaphragm cover by first engaging the top nipple, then place the bottom portion.</p> <p>Gently pull on the cover to ensure it is installed properly.</p>		
		
<p>Lubricate the hose o'ring and install.</p> <p>Install the pneumatic adjustment tool and attach the hose to the tool.</p>		

SCUBAPRO X650 SECOND STAGE

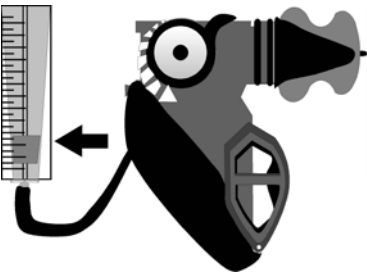
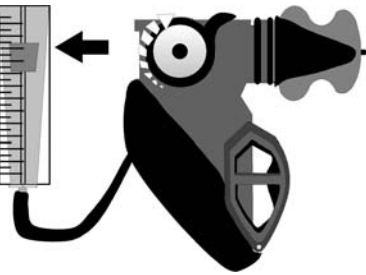
			
<p>Use the pneumatic adjusting tool to make the initial air-on adjustments to the second stage. The 3mm screwdriver can be used to make course adjustments on the balance chamber and to stop free flows.</p>			

			
<p>Adjusting the balance chamber counter clockwise reduces cracking effort.</p> <p>Adjusting the balance chamber clockwise increases cracking effort.</p>			

		
<p>Inspect and lubricate the external adjustment knob o’ring.</p> <p>Re-install external breathing adjustment knob and tighten using the Philips screwdriver.</p> <p>Make any additional adjustments using the pneumatic adjusting tool.</p>		

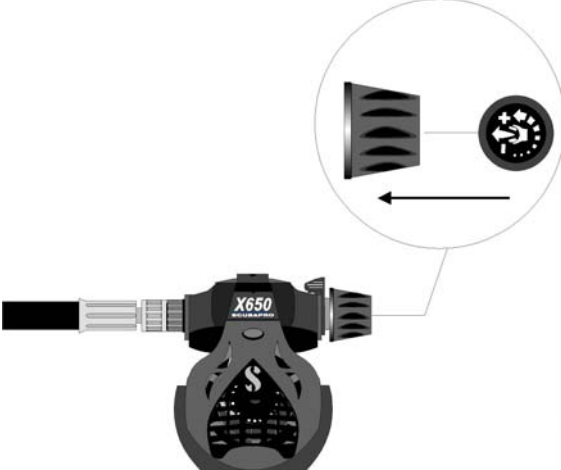
		<p>No tools needed this step</p>
<p>Install a new “Dive” decal if appropriate.</p>		

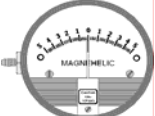
		
<p>Check the cracking effort of the regulator.</p> <p>Inhalation effort range: 1.0 to 1.4 inches of water.</p>	