

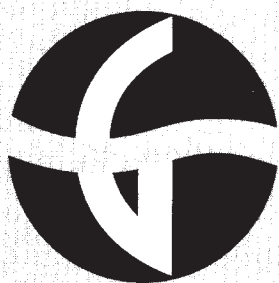

**REPAIR & SERVICE MANUAL**



**GF100 UNBALANCED**

**GF200 BALANCED**

**FIRST STAGE REGULATORS**



# CONTENTS

	<u>Page</u>
I. Introduction	1
II. Safety Precautions	1
III. General (User) Maintenance	2
IV. Scheduled Dealer Service	3
V. Disassembly	3
VI. Parts Cleaning	5
VII. Parts Inspection	6
VIII. Routine Replacement Parts	7
IX. Reassembly Procedure	7
X. Authorized Adjustment and Testing	8
TABLE 1 Troubleshooting Guide	10
TABLE 2 Test Bench Specifications	10
TABLE 3 Torque Specification	11
TABLE 4 Recommended Lubricants and Cleaners	11
TABLE 5 O-Ring Reference Chart	12
TABLE 6 Special Tools	12
Limited Lifetime Warranty (reprint from Owner's Manual)	13
Genesis Regulator Warranty - Dealer Procedure	14
First Stage - Exploded view and parts list	fold out
Defective Parts Claim Form	back cover

Technical assistance provided by Robert Ledbetter.

This service manual is copyrighted, all rights reserved. It may not, in whole or in part, be copied, photocopied, reproduced, translated or reduced to any electronic medium or machine readable form without prior consent in writing from Genesis Scuba®.

Genesis Scuba®, Origin™, Axis™, and Valor™ are trademarks of The Liberty Group, Inc.



---

## I. Introduction

Genesis SCUBA regulator repair manuals are written and provided to Authorized Genesis Dealers for use as a guide to assist in the maintenance, overhaul and trouble-shooting of Genesis SCUBA Regulators. This manual should be used only by personnel that have attended a sanctioned Genesis Regulator Repair Seminar, given by a representative designated by the Liberty Group.

To receive information about repair seminars in your region, contact your Genesis Distributor or sales representative for the date of the next Regulator Repair Seminar in your area. All employees of current Genesis dealers are encouraged to attend.

ANYONE ATTEMPTING TO SERVICE OR REPAIR A GENESIS SCUBA REGULATOR MUST HAVE ATTENDED A SANCTIONED REPAIR CLINIC. THE TECHNICIAN SHOULD HAVE A THOROUGH UNDERSTANDING OF THE PRINCIPLES OF OPERATION OF SCUBA REGULATORS AND VALVES, AS WELL AS THE APPROPRIATE MECHANICAL ABILITY. THE TECHNICIAN MUST ALSO BE FAMILIAR WITH THE SAFE USE OF COMPRESSED AIR AND THE TOOLS AND CLEANING SOLUTIONS INVOLVED IN THE PROCEDURES OUTLINED IN THIS MANUAL. THIS MANUAL IS NOT INTENDED TO BE USED AS A SELF-TEACHING GUIDE.



**NOTE:** Remember that you are working on life support equipment. Good workmanship and cleanliness are extremely important. Do not attempt to substitute parts that look similar from other manufacturers into Genesis regulators. Substitute parts can lead to malfunction or reduced performance.

## II. Safety Precautions

The following symbols are used throughout this manual to bring your attention to situations that require special consideration. Be sure to read and follow all instructions carefully.



A **WARNING** is used before a procedure that will result in serious injury or death if the procedure is not followed carefully.



A **CAUTION** is used before a maintenance technique that will result in damage to parts if that technique is not followed carefully.



A **NOTE** is used to emphasize an important maintenance technique.



### III. General (User) Maintenance

Providing the best possible preventative and routine maintenance before, after and between dive will help to ensure the maximum life of a regulator, and more importantly, proper function between servicing. To consistently achieve this goal, there are a number of simple, but important, routine maintenance procedures that should be followed by the customer after every use of the equipment. It is therefore important to advise the customer of the following recommended procedures:



**NOTE:** Refer the customer to the MAINTENANCE section of the GENESIS Regulator Owner's Manual.

#### POST-DIVE PROCEDURE

1. After each day of diving, the regulator must be cleaned, inspected and prepared for the next use, or for storage. As soon as the regulator is removed from the SCUBA cylinder, prepare the dust cap to be reinstalled over the regulator inlet port. Because the dust cap is normally attached to the regulator yoke, it has been underwater during the dive, so be sure to blow out all of the water in the dust cap before securing it over the inlet port. Failure to do this results in water or other contaminants entering the first stage, causing corrosion.

2. There are two methods of routinely cleaning regulators after each dive:

##### The Pressurized method

- a) Remove the dust cap. Attach the regulator to a charged SCUBA cylinder.
- b) Open the cylinder valve slowly to pressurize the regulator.
- c) Thoroughly soak both the first and second stage regulators in warm (not over 120°F) tap water to remove salt and mineral deposits. Direct water into the mainspring cavity of the first stage regulator, the second stage mouthpiece and the holes in the second stage front cover. Depress the purge button several times while the regulator is submerged in water. To remove excess water after soaking is complete, purge the second-stage a few more times.
- d) Close the cylinder valve and purge remaining air from the regulator. Remove the first stage from the cylinder.
- e) Dry the dust cap and place over the first stage inlet. Secure with the yoke screw.
- f) To air dry, lay the regulator on a clean towel, away from direct sunlight.

##### The Non-Pressurized method

The non-pressurized method can be performed if no charged cylinder is available.

- a) With the dust cap in place, thoroughly soak both the first and second stage regulators in warm (not over 120°F) tap water to remove salt and mineral deposits. After soaking, drain or blow all excess water out of the second stage.



**NOTE:** DO NOT DEPRESS THE PURGE BUTTON while soaking the second stage. Doing so will allow water to enter the hose and first stage.

- b) To air dry, lay the regulator on a clean towel, away from direct sunlight.

3. After drying, store the regulator as follows:

- a) Store in a clean equipment box, or as an alternative, seal in a plastic bag
- b) It is good practice to wipe rubber parts with a light application of silicone grease using an impregnated cloth if the regulator is to be stored for a long period of time.



**GENERAL CAUTIONS AND WARNINGS** - Whenever possible, be sure to advise your customers to take the following precautions while using or caring for their equipment.

**CAUTION:** First-stage regulators equipped with a DIN adapter must be cleaned with the pressurized method only, unless the inlet is covered with a threaded, o-ring sealed protective cap. Failure to adequately cover the DIN inlet will cause water to enter the first-stage, causing corrosion.

**CAUTION:** Do not expose any part of the regulator to silicone spray since some aerosol propellants attack, or degrade, rubber and plastic materials.

**CAUTION:** DO NOT use any type of solvent to clean any part of the regulator.

**CAUTION:** Never store the regulator while still connected to a SCUBA cylinder.

**CAUTION:** DO NOT carry the SCUBA cylinder by the regulator or hoses. Such abuse will eventually damage the regulator or the cylinder valve.

## IV. Scheduled Dealer Service

1. Do not assume that a regulator is in good working condition because of storage or infrequent use. Remember that even prolonged or improper storage can result in internal corrosion and/or deterioration of o-ring seals.
2. A regulator should be cleaned and adjusted frequently at a competent service facility (by a trained GENESIS repair technician). As an authorized GENESIS Scuba repair technician, it is your responsibility to inform your staff and customers that regulators require a complete servicing with scheduled parts replacement **at least** once a year in order to comply with the Limited Lifetime Warranty and 2 Year Parts Program for the regulator. **Failure to obtain service annually will void the warranty and parts program for the regulator.** The frequency of service should be appropriate for the frequency of use and the conditions under which the regulator is used. Use as rental or commercial equipment and/or use in salt, chlorinated (swimming pool) or polluted water might require cleaning and overhaul of the regulator more frequently. Chlorinated water is an especially bad environment for regulators since chlorine chemically deteriorates the neoprene rubber components.
3. Advise your customers to regularly inspect the filter in the inlet port of the first stage. If it is discolored or corroded, replacement by trained personnel is required. Also, the entire regulator may need a general overhaul with replacement of all soft seals and non-reusable components. Rust (red powder) or aluminum oxide (white/gray powder) deposits on the filter are usually an indication that water has entered the SCUBA cylinder and caused internal corrosion. The customer must be notified that their SCUBA cylinder(s) should be internally inspected and cleaned or hydrostatically tested as required.
4. When counseling your customers on preventative maintenance, inform them that no other adjustment or maintenance of their regulator is recommended by GENESIS Scuba. For adjustments such as intermediate pressure setting or proper lubrication, the regulator must be taken to an Authorized GENESIS Scuba Dealer.

## V. Disassembly

### GENERAL CONSIDERATIONS:

This section of the manual presents step-by-step disassembly procedures for the GF100 and GF200 first stage regulators. It is important that the sequence be followed exactly in the order given. Read over the entire manual prior to overhaul to become familiar with maintenance procedures. Take special note of all reference tables following these procedures.

Servicing of the first stage regulator should be carried out in a work area specifically set up and equipped for the task. Adequate lighting, cleanliness and easy access to all required tools are essential for an efficient repair facility. Special tools (see Table 6) are required for disassembly and subsequent assembly.

Before disassembling the first stage regulator, perform a pretest. By following the tests described on pages 8 and 9 and making reference to the Troubleshooting Guide, you will be able to determine the need for parts replacement.



**N NOTE:** Fold out the exploded view of the first stage assemblies from the back cover of this manual for easy reference during the service procedure.

1. Use an adjustable wrench to remove all hoses from the 1<sup>st</sup> stage body.

**N NOTE:** All hose o-rings should be replaced when the regulator is serviced. Be sure to replace o-rings with *exact* sizes as specified by the manufacturer(s) of second stages, gauges, and BC's.

2. Unscrew and remove the handwheel (item 2) and the dust cap (item 3).

3. Install a regulator support handle, or a spent CO<sub>2</sub> cartridge, into any low pressure port, taking care not to scratch the chrome.

4. Use a 15" adjustable wrench or bench vice with protected jaws to remove the yoke nut (item 5) or DIN adapter by turning in a counter clockwise direction.

5. Remove the yoke (item 4).

6. Use a 5/32" Allen wrench to remove all port plugs (items 14 & 16) from the body.

a. Remove o-rings from the port plugs.

b. Discard o-rings if worn or damaged.

7. Use a 15" adjustable wrench or bench vise with protected jaws to remove the end cap (item 26) in a counter clockwise direction.

8. Remove the piston (item 24) from the regulator body.

a. Remove the o-rings (items 22 & 25) from the piston and discard.

b. Remove the backup rings (items 23 & 28) from the piston and set aside.

c. Inspect the high pressure seat (item 21) before removal.

**N NOTE:** The condition of the seat is a good guide to the condition of the orifice. Pits or troughs in groove area of the seat may be an indication of a damaged or worn orifice sealing surface.

d. Insert the metal end of the H.P. Seat Tool (G1094-36) into the hole in the large end of the piston. A straightened paper clip may be used to remove the seat, but care must be used to prevent damage to the piston.

e. Ensure the tip of the tool is aligned into the smaller hole under the seat. Press out the seat and discard. *Figure 1.*

9. Using a small screwdriver, remove the tension clip (item 6) from the inlet (yoke end) of the regulator body

10. Remove the inlet filter (item 7).

a. Inspect the filter for evidence of aluminum oxide (white), rust (red/brown), or other contamination. If contaminants are visible in the filter, make a note on the repair documents to notify the customer that an inspection of his/her cylinder(s) is recommended.

b. Discard the filter after inspection.

**N NOTE:** Regulators that experience excessive service should have the inlet filter replaced more frequently to maintain adequate performance.

11. Insert the **blunt end** of the H.P. seat tool (G1094-36) into the end cap side of the regulator body. Gently push the orifice assembly out the inlet side of the regulator body. *Figure 2.*

**CAUTION:** Use care when handling the orifice assembly to prevent damage to the delicate sealing surface. Even minor damage can cause pressure creep and decreased performance.

a. Note the orientation of the spring washers (items 10), then remove by sliding them off the orifice stem.

b. Remove and discard the o-ring (item 11).

c. Remove the backup ring (item 12) and set aside.

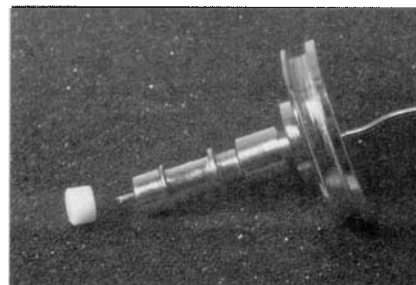

**Figure 1**

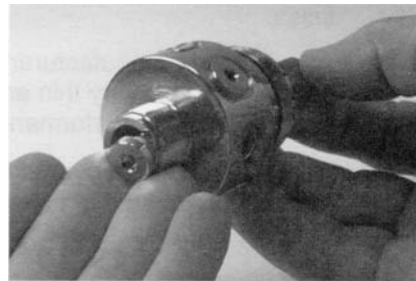

**Figure 2**



## DIN Adapter



**NOTE:** The DIN adapter is assembled using a thread locking compound on the internal threads. Service of the DIN adapter is usually limited to replacement of the external o-rings. Service or replacement of the internal o-ring is only necessary if the thread locking compound has been compromised, if any internal leak has been detected, or if the DIN adapter has incurred a substantial amount of use.

1. Remove the o-rings (items 30 and 35)
2. Align the flats on the handwheel (item 33) with corresponding wrench flats on the body (item 34) and place in a vice with soft jaws.
3. Unscrew the insert (item 31) using a ¼ " Allen wrench.
4. Remove o-ring (item 32) from the insert. Discard.
5. Clean the threads of the insert and body using a stiff nylon brush.
6. Lubricate and replace o-ring (item 32) onto the insert.
7. Place the handwheel on the body oriented with the grip area next to the wrench flats.
8. Place one drop of Loctite 259 on the threads of the insert. Screw into the body and tighten to 12 ft lbs.

## VI. Parts Cleaning



**CAUTION:** NEVER expose plastic or rubber parts to solvents, acidic, or caustic cleaning agents of any type. Never use aerosol silicone sprays to lubricate or clean plastic or rubber parts. The propellant or solvents may attack or weaken the plastic material.

1. All o-rings and seats are routinely replaced during a general overhaul.
  - a. All of the parts in the repair kit should be installed in the regulator, and the used parts discarded.
  - b. A list of the parts to be replaced during routine maintenance is on page 7 of this manual.
2. All reusable plastic and rubber parts should be cleaned in fresh, warm (not over 120°F) water with a mild detergent. Use a soft nylon brush, if necessary, taking care not to scratch or abrade the rubber or plastic parts..
  - a. Rinse in clean, fresh water.
  - b. Blow dry with low pressure air (less than 30 psi.)
  - c. Inspect the parts for cracks, burrs, distortion and solvent attack.

3. Use a soft nylon brush to loosen and remove any loose or flaking material from all metal parts.



**CAUTION:** The orifice (item 8) should be cleaned and rinsed separately to prevent damage to the sealing surface. Avoid contact with other parts, tools, or hard surfaces.

4. Place metal parts in suitable cleaning solution (see list on page 11).
  - a. Genesis recommends the use of an ultrasonic cleaner, and mixing cleaning materials to manufacturer's specifications.
  - b. If a 50% vinegar/50% water solution is used, check parts frequently to avoid deterioration of the finish.
  - c. Always follow manufacturer's recommendations for dilution and soak times. The plating on interior bore surfaces is very thin and can easily be damaged. Subsequent corrosion of unprotected brass can lead to early performance deterioration.



**CAUTION:** Do not over use acid solutions, damage to plated surfaces may result. NEVER use a wire brush to remove mineral encrustation or corrosion. Damage to plated surfaces or orifice sealing surfaces may result.

- d. If no ultrasonic cleaning tank is available, use the cleaning solution mixed to manufacturer's specifications, or 50% water/50% white vinegar solution. Immerse metal parts and gently agitate for three to four minutes. Check frequently.
5. Thoroughly rinse the clean parts in fresh water, and blow dry with low pressure air (30 psi or less.)



---

## VII. Parts Inspection

1. All of the parts in the kit should be inspected before use. Look for contaminants and molding flaws before installation.
2. All reusable metal components must be inspected for burrs, scoring and corrosion. Genesis strongly recommends the use of a strong light and magnifying lens to aid inspection.
3. Replace components if you find:
  - a. blistered, peeling or cracked chrome;
  - b. damaged threads, cross-threaded or stripped threads;
  - c. scratches or damage to o-ring sealing surfaces;
  - d. nicks, burrs, scoring or scratches that could effect sliding or rotating parts;
  - e. solvent attack, deformation, cracking or distortion of plastic parts;
4. Pay specific attention to the following parts and replace if necessary.
  - a. Examine the orifice (item 8) for scratches, nicks, excessive wear or damage to the plating. Inspect the o-ring groove.
  - b. Examine the regulator body (item 13) for internal scratches or corrosion damage, and damage caused by excessive use of acid cleaning solutions that could cause o-ring sealing problems.
  - c. Examine the end cap (item 26) for internal scratches or corrosion damage, and damage caused by excessive use of acid cleaning solutions that could cause o-ring sealing problems.
  - d. Examine the threads on the regulator body, end cap (item 26), and yoke nut (item 5).
  - e. Examine the o-ring grooves in the piston (item 24) for scratches and nicks.
  - f. Inspect the hose for cuts, nicks, cracking, or hardening. Pay particular attention to the outer jacket at the hose ends. Look for damage around the crimped portion of the hose fittings. If the braided reinforcement is showing or there is evidence that the hose is pulling out of the fittings, replace the hose. Inspect the threads on the hose fittings and the o-ring seating surfaces. Replace if necessary.

**Refer to Table 1 Troubleshooting Guide for additional problem areas.**





## VIII. Routine Replacement Parts

These parts are included in Genesis First Stage Parts Kit PK100 and should be replaced during all routine maintenance.

Item Number	Part number	Description	Qty Needed
7	GF1-07	inlet filter	1
11 & 22	RM214E	o-ring	2
18	RM048E	o-ring	1
21	GF1-21	H.P.seat	1
25	RM139E	o-ring	1

**N** **NOTE:** Genesis recommends that all of the parts in the Routine Replacement Parts list be replaced every year for regulators used by recreational divers. Heavily used rental regulators and commercially used units should be serviced on more frequent intervals, based on their level of use and abuse.

## IX. Reassembly Procedure

1. Lay out all parts on a clean working surface.
2. Reassemble the Orifice
  - a. Once again inspect the cone of the orifice (item 8) for dings, scratches or corrosion. If necessary, use a pencil eraser to gently polish the cone surface. Defects will show as dark areas. A strong light and magnifying lens will make inspection easier.
  - b. Lightly lubricate the o-ring (item 11) and roll it into the o-ring groove on the orifice.
  - c. Gently stretch the backup ring (item 12) onto the end of the orifice and back into the o-ring groove.
  - d. Determine if orifice is one that requires spring washers.
    - i. The orifice assembly for an *unbalanced* (Origin) first stage should appear like *Figure 3a.*, and is ready to install.
    - ii. The orifice assembly for a *balanced* first stage should appear like *Figure 3b.*, and must have the spring washers (items 10) installed. Verify the correct spring washer orientation as shown.

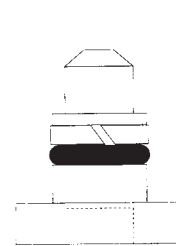

**Figure 3a**

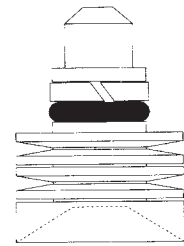

**Figure 3b**

**N** **NOTE:** Genesis 1<sup>st</sup> Stages can be either balanced or unbalanced. The orifices are interchangeable and an Origin can be upgraded to balanced performance with a simple and inexpensive orifice change.

3. Press the orifice assembly into the regulator inlet with the tip of your finger.
4. Place a new filter on top of orifice; smoothest side toward the orifice.
5. Push the tension clip into the regulator inlet until it touches the filter.
6. Reassemble the piston
  - a. Gently stretch the backup ring (item 23) and place into the groove on the stem of the piston.
  - b. Lightly lubricate the o-ring (item 22) and roll it into the groove on the stem of the piston.
  - c. Lightly lubricate the large piston o-ring (item 25) and roll into the groove in the flange of the piston.
  - d. Place a new H.P. seat (item 21) on a clean pad on your work surface.
  - e. Orient the piston such that the seat cavity is directly over the new seat. Gently push the piston down onto the seat. *Figure 4.*
7. Replace all shims (item 20) that were removed during disassembly into the regulator body (item 13) from the end cap side.

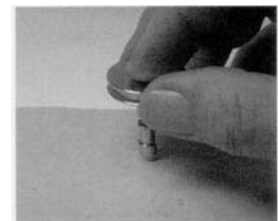

**Figure 4**

**N** **NOTE:** Use no more than 3 shims in a Genesis first stage. Refer to Troubleshooting for additional information about adjusting hose pressure.



8. Place the spring (item 19) into the regulator body.
9. Lightly lubricate the o-ring (item 18) and gently stretch it into the o-ring groove on the body.
10. Insert the piston through the spring and into the inner bore of the regulator body.
11. Lightly lubricate the threads on the end cap (item 26) and screw the end cap onto the body. Tighten to 12 ft lbs. (16 Nm).
12. Yoke assembly installation
  - a. Lightly lubricate the threads on the yoke nut (item 5).
  - b. Place the yoke (item 4) on the regulator inlet.
  - c. Secure with the yoke nut (item 5) tightened to 12 ft lbs. (16 Nm).
  - d. Install the dust cap (item 3) onto the threads of the handwheel (item 2).
  - e. Lightly lubricate the handwheel threads and install into the yoke.
13. DIN adapter installation. (Refer to DIN adapter service procedure in Section V. Disassembly.)
  - a. Lightly lubricate the internal threads of the DIN adapter.
  - b. Screw the DIN adapter onto the regulator body inlet.
  - c. Align the flats on the handwheel with corresponding wrench flats. Use a 15 " adjustable wrench and tighten to 12 ft lbs. (16 Nm).

## **X. Authorized Adjustment and Testing Procedures**

1. Install the regulator on a SCUBA tank or test bench with a supply pressure of 2900 to 3200 psi.
2. A working second stage or over-pressure relief assembly should be installed on one of the low pressure ports to protect the test gauge and technician.
3. Install an intermediate pressure test gauge, G1116-80, into one low pressure port.
4. Plug all remaining ports.
5. SLOWLY turn on the air and watch the gauge.
  - a. Listen for any unusual leaks. If any are heard, turn off the air and correct the problem before proceeding
  - b. Press the second stage purge button or relief valve several times to allow the new parts to seat themselves.
  - c. The pressure should rapidly rise and remain steady between 135 and 150 psig.
    - i. There should be no more than 5 psig of creep within 15 seconds of cycling the regulator.
    - ii. It is normal for piston regulators of this design to experience a slight drop in pressure after lockup, due to the superior efficiency of design.
    - iii. If the pressure continues to rise above 150 psig, turn off the air and disassemble the first stage to find and correct the problem. Refer to Troubleshooting for additional information.
      - A simple removal of shims (item 20) may be all that is required.
      - Inspect the H.P. seat (item 21) and orifice (item 8) for defects.
      - Correct the problem and begin again with step 5.
    - iv. If the pressure is below 135 psig, add shims in the main spring area to raise pressure. Use no more than 3 shims in a Genesis first stage. If the maximum number of shims is already present, replace the main spring, reassemble, and retest.



- 
- d. Slowly release a small amount of air from the gauge or second stage.
    - i. Hose pressure should not drop more than 5 psi.
    - ii. When the air flow is stopped, the pressure should immediately return to 135 - 150 psig and remain steady
  6. Place the regulator on a cylinder or test bench with supply pressure of 300 - 500 psig.
  7. SLOWLY turn on the air and watch the gauge.
    - a. Origin first stage: Hose pressure should drop no more than 20 psi from the initial reading at high source pressure.
    - b. Axis & Valor first stages: Hose pressure should drop no more than 5 psi from the initial reading at high source pressure.
    - c. Greater pressure drops indicate a sealing problem between the piston seat (item 21) and the orifice (item 8).
      - i. Remove the regulator from the air source.
      - ii. Remove the end cap and piston.
      - iii. Examine the high pressure seat for damage or foreign particles. Clean or replace as necessary
      - iv. Remove the retainer ring and filter from the regulator inlet.
      - v. Insert the **blunt end** of the H.P. seat tool (G1094-36) into the end cap side of the regulator body. Gently push the orifice assembly out the inlet side of the regulator body.
      - vi. Examine the sealing surface of the orifice for damage. Clean or replace as necessary.
      - vii. Reassemble and retest (Step 5 above).
  8. Install the first stage assembly on a full SCUBA cylinder.
  9. SLOWLY turn on the air supply.
  10. Submerge the entire first stage assembly in water and gently agitate to dislodge any bubbles. There should be no bubbles leaking from the assembly. If bubbles appear, determine the source of the leak, disassemble to replace any worn parts, reassemble and retest (Step 5).



## TABLE 1 Troubleshooting Guide Genesis 1<sup>st</sup> Stage Regulators

Problem	Probable Cause	Recommendation
<b>Creeping (slowly rising) hose pressure.</b>	Damage to the orifice (item 8).	Inspect the orifice with a high powered light and magnifying lens. Replace if necessary.
	Corrosion on orifice (item 8).	Try polishing the orifice with a pencil or typewriter eraser using light pressure. Replace if necessary.
	Contamination on piston seat (item 21).	Inspect indentation for rust, aluminum oxide, sand, or other contamination. Replace if necessary.
	Defect in piston seat (item 21).	Inspect the seat with a high powered light and magnifying lens. Replace if necessary.
<b>Hose pressure above 150 psig., and steady.</b>	Too many shims (item 20) in spring chamber.	Remove one or more shims.
	Improper spring (item 19).	Replace.
	Defect in piston seat (item 21).	Inspect the seat with a high powered light and magnifying lens. Replace if necessary.
	Damage or corrosion on sealing surface of orifice (item 8).	Inspect the orifice with a high powered light and magnifying lens. Replace if necessary.
	Wrong orifice (item 8) used with spring washers (item 10).	Only orifice GF2-08 may be used with spring washers. See Figure 3b, for visual reference of orifice GF2-08.
<b>Hose pressure below 135 psig., and steady.</b>	Adjustment required	Add shims (item 20) under spring, up to 3 maximum.
	Wrong or weak spring (item 19)	Replace.
	Balanced orifice assembly missing one or more spring washers (item 10).	See Figures 3a & 3b for visual references of unbalanced and balanced orifice assemblies.
<b>Noise on inhalation</b>	Harmonic vibration of spring and/or piston.	Confirm backup rings and o-rings are properly installed on piston. Distribute shims on both ends of spring, turn the spring over, or replace spring.

## TABLE 2 Test Bench Specifications

Test	Condition	Acceptable Range
Leak Test	inlet pressure: 3000 - 3500 psig	No leaks allowed
Intermediate pressure	inlet pressure: 3000 - 3500 psig	hose pressure: 143 ± 7 psig
Intermediate pressure creep	inlet pressure: 3000 - 3500 psig	hose pressure should not change more than 5 psig within 15 seconds after purging regulator



### TABLE 3 Torque Specifications

Part Number	Description / Item Number	Torque
GF1-26	End Cap / item 26	12 foot pounds
GF1-05	Yoke Nut / item 5	12 foot pounds
GF1-31	Din Insert / item 31	12 foot pounds
DIN300	DIN Adapter to Regulator	12 foot pounds
1022-36	Regulator Hose Assembly, and all accessory hoses	40 inch pounds

**N** **NOTE:** All hoses attached to the regulator, including gauge and BC inflator hoses, should be installed to 40 inch pounds of torque before any leak tests are performed.







### TABLE 4 Recommended Lubricants and Cleaners

Item	Application	Source(s)
Loctite 259	Assembly of DIN adapter (DIN300)	Genesis distributor Loctite ( <a href="http://www.loctite.com">http://www.loctite.com</a> )
Dow Corning DOW-111	For regulators in service with air only (21% oxygen max.). All o-rings and threaded metal parts.	Genesis distributor
Christo Lube 111	For regulators in service with air or enriched air mixtures. <i>See Note below.</i> All o-rings and threaded metal parts.	Genesis distributor, Lubrication Technology, Inc. 310 Morton Street Jackson, Ohio 45640
<p><b>NOTE:</b> Use only a light film of lubricant. Do not use silicone spray. Sprays leave very little lubricant after the propellant evaporates and the propellant in many sprays attacks plastic and rubber parts.</p> <p><b>NOTE:</b> Use of regulators with enriched air mixtures (over 21% oxygen) requires special cleaning, handling, and maintenance techniques. The standard model Genesis regulators are not intended for use with enriched air mixtures.</p>		
Ultrasonic cleaner with ultrasonic detergent	Mixed according to manufacturer specifications. All metal regulator parts	Dental supply houses Ultrasonic manufacturers
Oakite #31	All metal regulator parts	Oakite Products, Inc 50 Valley Rd. Berkeley Heights, NJ 07922
Lawrence Factor LWF	All metal regulator parts	Lawrence Factor (305) 430-0550
White Distilled Vinegar	50/50 solution with fresh water. All metal regulator parts	Grocery Stores
Liquid dishwashing detergent	All reusable parts	Grocery Stores



## TABLE 5 O-Ring Reference Chart

This chart is provided to help you identify the o-rings included in the parts kits. All sizes are approximate. DO NOT use this chart as a guide for selecting substitute o-rings.

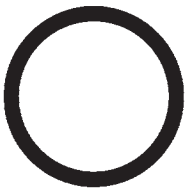
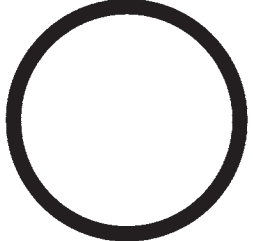
	RM855E	LP port plug		R014E	Din adapter, item 35
	RM214E	Orifice, piston		RM675E	DIN adapter, item 32
	R011E	Hose end, male HP port plug		RM717E	DIN adapter, item 30
			RM139E	Piston	
			RM048E	Body	

## TABLE 6 Tools



G1116-10	Hose Pressure Test Gauge, Small adjustable wrench Large adjustable wrench Torque wrench with crow's foot	Regulator support (or spent CO2 cartridge)
G1094-36	Seat tool	

Additionally, the technician should have a complete set of wrenches, common tools, a source for high pressure and low pressure breathing air, and a clean well lighted work area. A professional flow bench is highly recommended for making accurate adjustments.



## Limited Lifetime Warranty (as printed in the Genesis regulator Owner's Manual)

*GENESIS regulators are warranted to be free of defects in materials and workmanship for as long as you own the regulator.* This warranty originates at the date of consumer purchase from an authorized GENESIS retailer. The warranty is limited and subject to the restrictions listed below.

### **What is covered**

All parts of your Genesis regulator are covered under this warranty. Should any part of your Genesis regulator be found *defective*, Genesis Scuba, at its discretion, will repair or replace the component at no charge to you.

### **What is not covered**

Inspection, service, and/or labor charges will be paid by the regulator owner.

Some regulator parts are subject to wear even under normal or minimal use. O-rings, high pressure seats, low pressure seats, filters, star washers, diaphragms, exhaust valves, tie wraps, mouthpieces, and hoses should be inspected for excessive wear on a regular basis. Replacement of worn items constitutes normal maintenance, and is the responsibility of the owner. *See the GENESIS 2 Year Parts Program below.*

This warranty does not cover damage to the product resulting from the introduction of rust or other contaminants from the air supply, normal wear, improper usage, improper maintenance, neglect of care, alteration, or unauthorized repair. This warranty will automatically become void if proper preventative maintenance procedure have not been followed as outlined in this manual.

All repairs made, not covered under the terms of this warranty, will be made at the owner's expense.

### **What you need to do**

Keep a copy of the original purchase receipt and subsequent inspections with this manual.

Your GENESIS regulator must be inspected and serviced by a qualified GENESIS repair facility within 6 weeks before or after the one year anniversary date of your purchase or last servicing. Service must take place at least annually, or more frequently with heavy use. See your authorized GENESIS retailer if you have questions regarding the recommended frequency of service. Failure to have your regulator inspected/serviced within the specified time will void the warranty.

The repair facility must sign your service registration log at each annual inspection. Failure to do so will void the warranty.

Put this manual, your original purchase receipt, and subsequent inspection receipts in a safe place for future reference.

This warranty is nontransferable from the original owner. No salesperson, dealer, or representative is authorized to make any modification to this warranty.

ALL IMPLIED WARRANTIES, INCLUDING BUT NOT LIMITED TO THE IMPLIED WARRANTIES OF MERCHANTABILITY AND FITNESS FOR A PARTICULAR PURPOSE ARE LIMITED TO THE DURATION OF THIS WRITTEN WARRANTY. Some states do not allow limitations on the duration of implied warranties so this may not apply to you.

GENESIS SCUBA SHALL NOT BE LIABLE OR RESPONSIBLE IN ANY MANNER FOR LOSS OF USE OF THE PRODUCT OR ANY INCIDENTAL, CONSEQUENTIAL, OR INDIRECT COSTS, EXPENSES OR DAMAGES INCURRED WITH THE USE OF THE GENESIS REGULATOR. Some states do not allow this exclusion so this limitation may not apply to you.

This warranty gives you specific legal rights. You may have rights which will vary from state to state.

### **GENESIS 2 Year Parts Program**

Genesis Scuba will provide the annual service kits for your Genesis regulator for your first two annual service/inspections. The service kits contain all the standard overhaul parts that Genesis recommends be replaced at least on an annual basis.

The GENESIS 2 Year Parts Program is automatic but you must adhere to the stipulations of the Limited Lifetime Warranty to keep it in effect.

- Your regulator must be inspected/serviced only by an qualified GENESIS repair facility.
- Your regulator must be inspected/serviced within 6 weeks before or after the one year anniversary date of your purchase or last servicing.
- Keep a copy of the original purchase receipt and subsequent inspections with this manual.
- Inspection, service, and/or labor charges will be paid by the regulator owner.

This program is nontransferable from the original owner.



# Genesis Regulator Warranty - Dealer Procedure

## At the time of sale:

1. Complete the Inspection Record on page 15 of the Regulator Owner's Manual. The purchase date, model of regulator, service technician's name and serial numbers of both first and second stages must be recorded on this page. The customer needs to keep this information and the transaction receipt as a record of the original purchase.
2. You also need to let your customer know that this record (the Regulator Owner's Manual and receipt) is important and must be presented to the service facility to take advantage of the 2 Year Parts Program and Limited Lifetime Warranty. Recommend the customer keep these items in a safe, accessible place - with his/her logbook for instance.

## When it's time for service:

In order to keep the Limited Lifetime Warranty and 2 Year Parts Program in effect, the customer must provide: the regulator, the owner's manual, the original sales receipt, and receipts or records of any subsequent service.

## You need to:

1. Verify ownership of the regulator. The warranty and parts program are only eligible to the original retail purchaser.
2. Verify warranty is in effect. Service must take place within one year of the original purchase date,  $\pm 6$  weeks; or within one year of the last service procedure,  $\pm 6$  weeks. Additional service procedures will not affect the warranty, however, exclusion of an annual service procedure within the specified time frame will void the warranty and parts program.
3. Determine if 2 Year Parts Program is in effect. The 2 Year Parts Program provides a free parts kit for each of the first two annual service procedures as long as the customer has kept the warranty in effect.
  - 2 Year Parts Program in effect.** Cut out the applicable coupon from the inside back cover of the Owner's Manual. Completely fill out all information on the coupon. ALL information must be provided to obtain parts kit replacement.
  - 2 Year Parts Program expired or void.** Notify the consumer of the warranty status of this regulator and estimate his/her parts costs before beginning the service procedure.
4. Service the regulator with appropriate parts kit. Each kit contains all the standard overhaul parts that Genesis recommends be replaced at least on an annual basis.
5. Record the service on page 15 of the regulator owner's manual. The repair facility must sign the Inspection Record at each annual service. Failure to do so will void the warranty.
6. Return the regulator and the owner's manual with all dated receipts and records to the customer. Again, stress to the owner the importance of keeping all receipts for verification of warranty status in the future. It is a good idea to staple the receipts inside the back cover of the regulator Owner's Manual.
7. Send the completed coupon to your Genesis Scuba distributor. Your distributor will replace the coupon with a new kit of the same parts.

## Defective Parts

Should any part of a Genesis regulator be found defective in materials or workmanship, Genesis Scuba, at its discretion, will repair or replace the component at no charge to the dealer. Please refer to the warranty statement on the previous page for explanations and examples of items that are, and are not, covered by this warranty. Defective parts should be sent to your Genesis distributor along with a completed Defective Parts Claim Form. (Forms are available from your Genesis distributor, or you may photocopy the form on the next page.) ALL information must be provided for the claim to be processed. Contact your Genesis distributor to obtain a Returned Goods Authorization number and other shipping instructions. Shipments without an RGA number visible will be refused and returned to sender.

This form is *not* to be used for normal, regular maintenance items, seats, o-rings, etc.

## Rental

All regulators used in rental service have a Limited Lifetime Warranty to be free of defects in materials and workmanship as long as the dealer owns the regulator. The warranty is not transferable. All repairs on these regulators are to be maintained by the dealer. All defective parts will be evaluated by Genesis Scuba, and at their discretion, will repair or replace the component to the dealer. Defective parts need to be returned with a RGA number and a Limited Lifetime Warranty Defective Parts Claim Form. The form is not used for items replaced for annual maintenance.



# FIRST STAGE PARTS



Item	Part #	Description
1	GF1-01	label, handwheel
2	GF1-02	handwheel
3	GF1-03	dust cap
4	GF1-04	yoke
5	GF1-05	yoke nut
6	GF1-06	tension clip
7	GF1-07	inlet filter
8	GF1-08	orifice, unbalanced
	GF2-08*	orifice, balanced
10	GF2-10*	spring washers (4)
11	RM214E	o-ring
12	GF1-12	backup ring
13	GF1B	body
14	GF1-14	plug, HP port
15	R011E	o-ring
16	GF1-16	plug, LP port
17	RM855E	o-ring
18	RM048E	o-ring
19	GF1-19	main spring
20	GF1-20	shim
21	GF1-21	seat
22	RM214E	o-ring
23	GF1-12	backup ring
24	GF1-24	piston, bare
25	RM139E	o-ring
26	GF1-26	cap
27	GF1-27	label, cap
28	GF1-28	backup ring

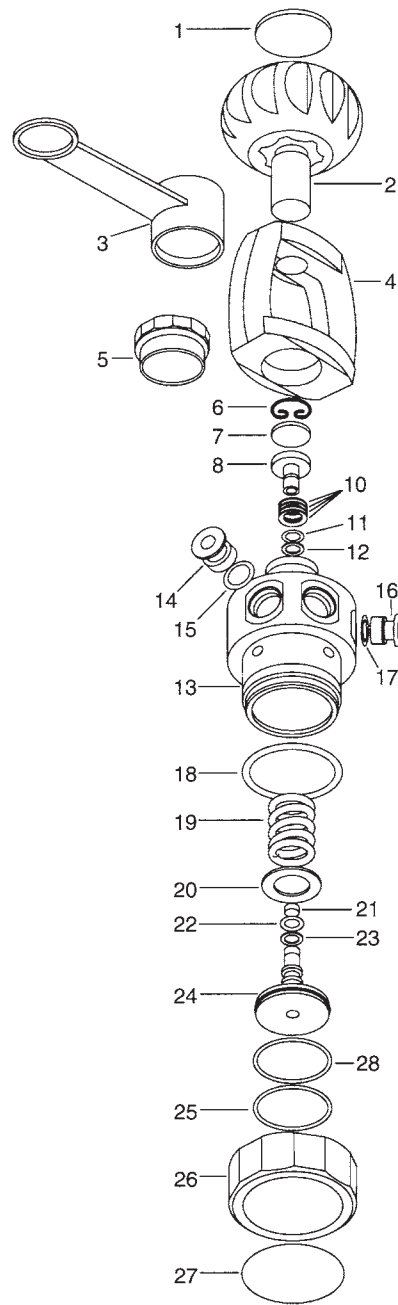

## DIN Adapter Parts

Item	Part #	Description
30	RM717E	o-ring
31	GF1-31	insert
32	RM675E	o-ring
33	GF1-33	handwheel
34	GF1-34	body
35	R014E	o-ring

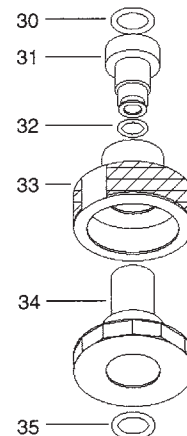

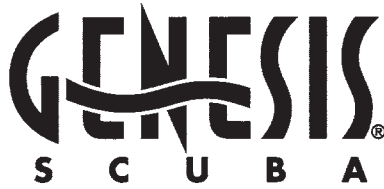

## Limited Lifetime Warranty - Regulators Defective Parts Claim Form

Use this form to submit parts that are defective in materials or workmanship to your Genesis distributor. Should any part of a Genesis regulator be found defective, Genesis Scuba will, at its discretion, repair or replace the component at no charge to the dealer. Contact your Genesis distributor to obtain a Returned Goods Authorization number and other shipping instructions. Shipments without an RGA number visible will be refused and returned to sender. ALL information must be provided and legible on this form for the claim to be processed.

This form is *not* to be used for normal, regular maintenance items, seats, o-rings, etc. Refer to the Genesis Limited Lifetime Warranty for further explanation of parts that are, and are not, covered under this warranty.

**Warranty Verification** (must meet both of the following)

- Original Owner verified by original bill of sale
- Annual service verified by receipt(s) for previous annual service(s)

Owner Information
Name
Regulator model
1 <sup>st</sup> Stage Serial number
2 <sup>nd</sup> Stage Serial Number
Original date of purchase
Date of this service

Dealer Information
Store name
Address
Phone
Technician name
Signature

Defective Part(s)		
Part number	Description	Nature of defect