

SCUBAPRO

Repair Guide

AIR 2

Alternate Inflator Regulator

**USE THIS GUIDE AS A REFERENCE WHEN SERVICING
THE AIR 2 (3rd and 4th Generation)**

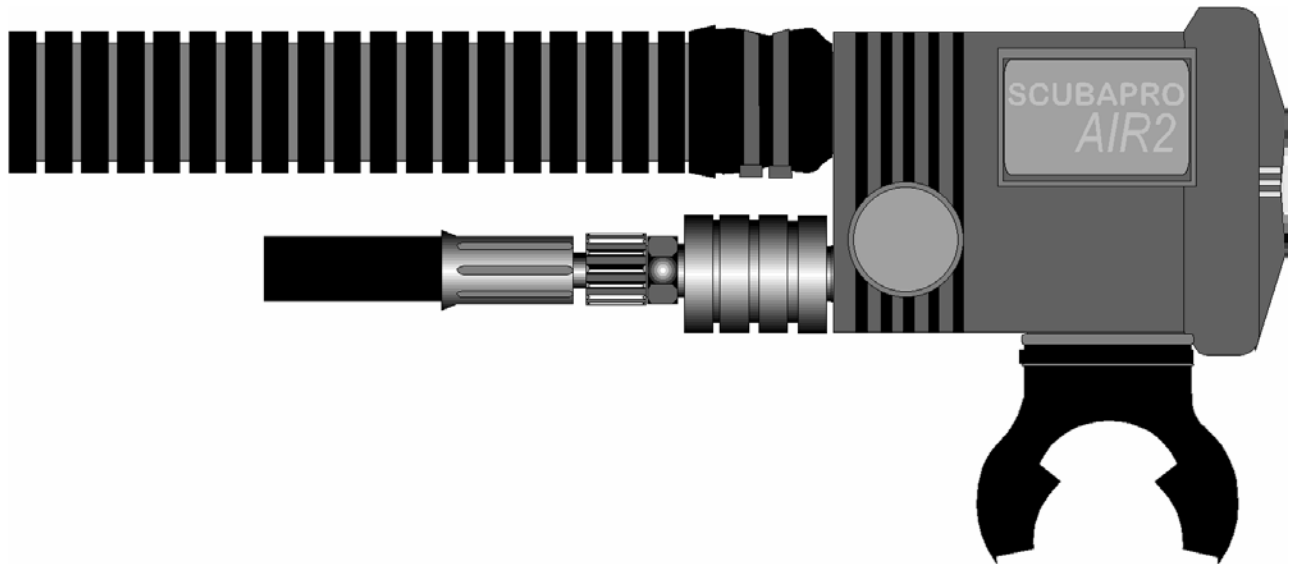

©2003 SCUBAPRO

important note: The following information is not designed to be a complete training guide for servicing the listed SCUBAPRO regulators. All SCUBAPRO technicians are required to attend an annual service training program to insure safe handling and servicing of SCUBAPRO products. All SCUBAPRO technicians must be employed by an authorized SCUBAPRO facility.

TOOLS NEEDED FOR REPAIR OF AIR2



Quantity	Part Number	Description	
1 set	10.102.100 (Peter Built)	Brass o'ring picks	
1 tube	41.047.000	Christo-Lube	
1	47.010.000	Counter Mat	
1	41.496.101	Lubricant syringe	
2		Adjustable wrench	
1		Small screwdriver	
1	20-136-100	Air 2 Spider Tool (Peter Built)	
	20-125-200	Seat Slider (Peter Built)	
1	20.500.200 (Peter Built)	Pneumatic Adjusting tool	
1	18.300.500	Blow Gun/Air Nozzle	
1		1/4" Nut Driver	
1	43.040.000	Universal Tool	
1	79-400-505	Magnehelic Gauge (Peter Built)	
1		Torque Wrench - 100 in-lb range	





ICON LEGEND

	Inspect carefully, replace if needed
	Lubricate properly
	Replace annually
	Dynamic o'ring, replace annually and lubricate properly
	No tools needed for this step

©2003 SCUBAPRO

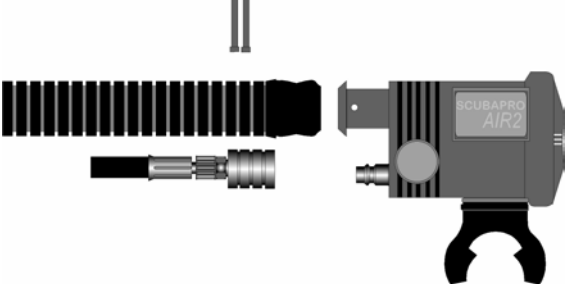
Important note: The following information is not designed to be a complete training guide for servicing the listed SCUBAPRO regulators. All SCUBAPRO technicians are required to attend an annual service training program to insure safe handling and servicing of SCUBAPRO products. All SCUBAPRO technicians must be employed by an authorized SCUBAPRO facility.

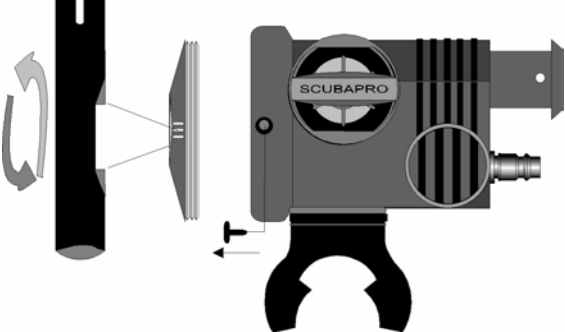
SCUBAPRO AIR2 3rd & 4th Generations

		No tools needed this step
Remove hoses from unit.		
		
Remove the alignment pin using a pick. Use the Seat Slider to remove the front cover as shown.		
		No tools needed this step
Remove the cover, friction ring and diaphragm. Note the position of the lever and air barrel.		



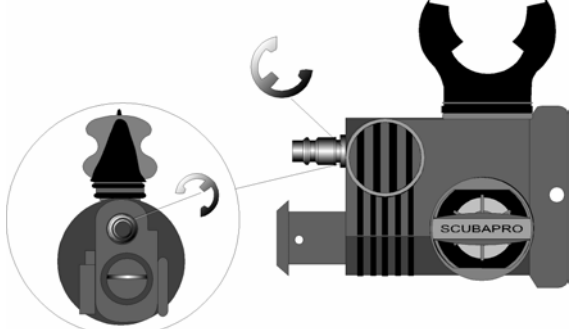

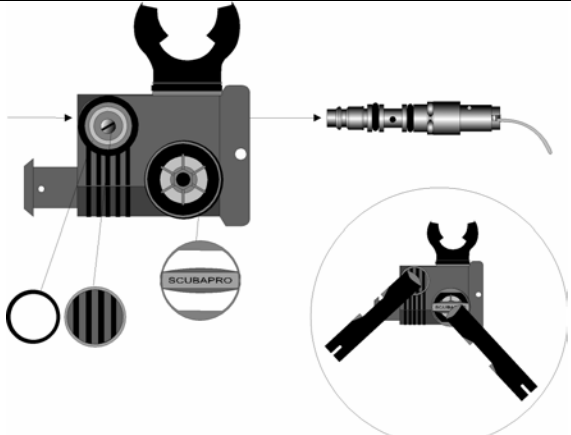
SCUBAPRO AIR2 3rd & 4th Generations

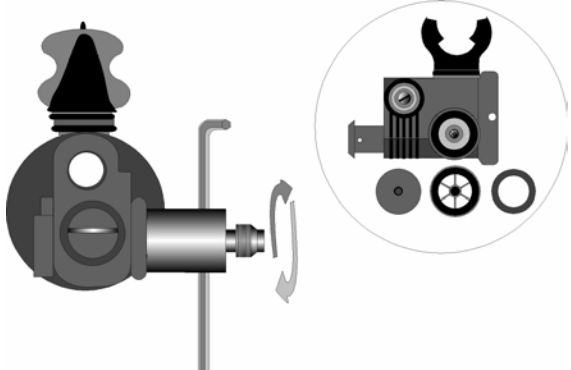
	
<p>Remove the “c” clip using a pick or other tool.</p> <p>Avoid scratching the Air 2 body with a sharp instrument.</p>	



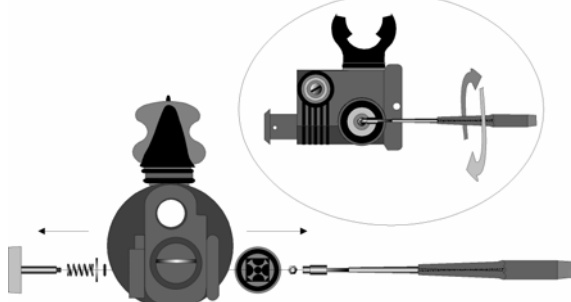

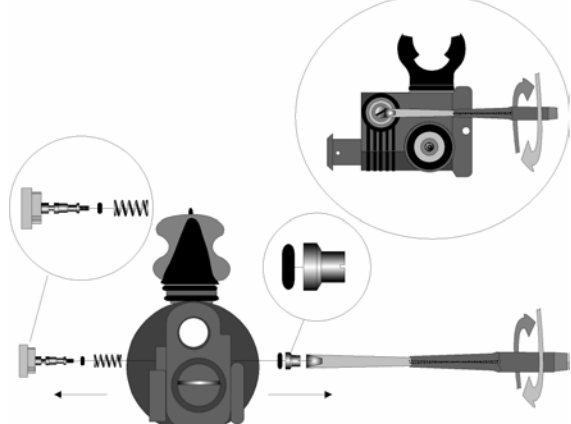

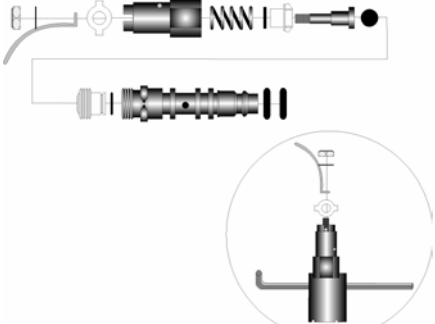
	
<p>Push the air barrel forward, removing it through the front cover area.</p> <p>Use the seat slider tool to loosen and remove the covers for the exhaust valve and the inflation valve.</p>	

	
<p>Use the Air 2 spider tool to loosen the exhaust valve “spider.” Remove the spider, exhaust valve, and washer.</p>	

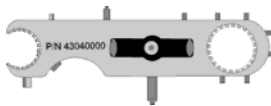

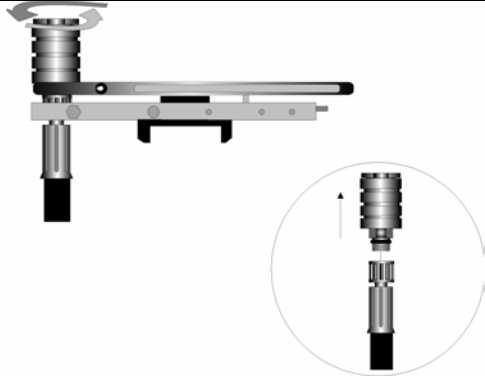
SCUBAPRO AIR2 3rd & 4th Generations

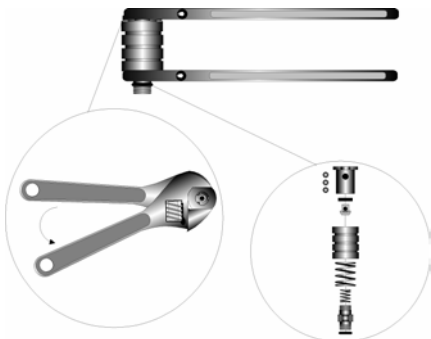
	
<p>Remove the nyloc nut holding the exhaust seat assembly together.</p> <p>CAUTION: Hold the exhaust button in while performing this step to prevent loss of spring.</p>	
	
<p>Carefully remove the inflation seat.</p> <p>CAUTION: Keep constant pressure on the inflation button while loosening to prevent loss of the spring.</p>	
	
<p>Disassemble the air barrel and all of its components.</p> <p>Use the Air 2 spider tool to apply pressure to the downstream valve components. This will facilitate removal of these parts.</p>	

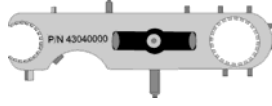
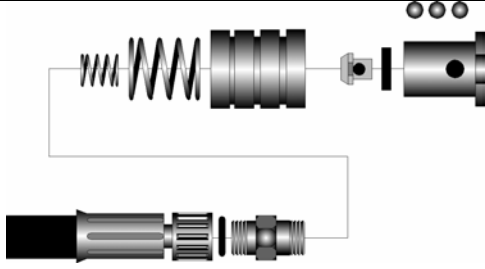
SCUBAPRO AIR2 3rd & 4th Generations

		
<p>If needed, disassemble and clean the quick-disconnect inflator mechanism.</p> <p>Use the universal tool to hold the splined hose fitting. Remove the quick disconnect mechanism from the hose using an adjustable wrench.</p>		
	 <p>(2)</p>	
<p>Disassemble the quick disconnect mechanism and check the seat for wear. Use this opportunity to clean the components.</p> <p>CAUTION: Disassemble the mechanism carefully to avoid losing the three bearings.</p>		
	 <p>(2)</p>	
<p>Reassemble the quick disconnect mechanism and tighten.</p>		

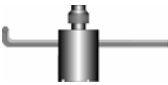
SCUBAPRO AIR2 3rd & 4th Generations

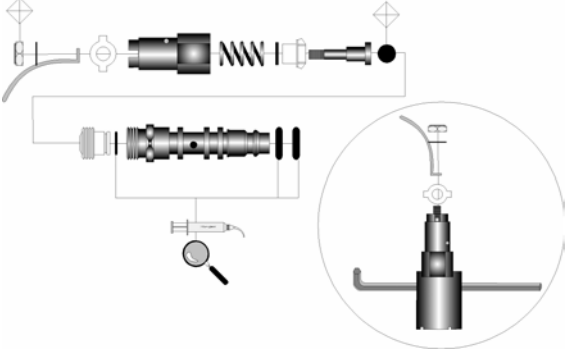
			
<p>Replace all annual replacement components (seat and nyloc nut).</p> <p>Inspect and lubricate all o'rings.</p> <p>Reassemble the air barrel. Use the Air 2 spider tool to assist in replacing the nyloc nut and valve assembly.</p>			

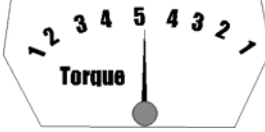
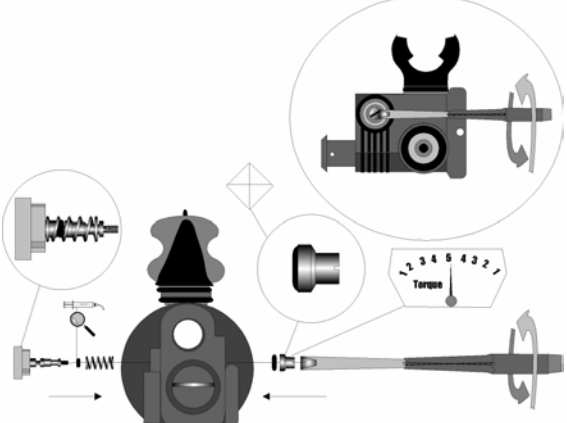
		
<p>Replace the inflator seat. Thread onto the end of the inflator button as shown. Hold the inflator button down to prevent loss of spring while threading the seat in place.</p> <p>Torque to 2.7 in-lbs or 0.3 Newton Meters.</p>		

SCUBAPRO AIR2 3rd & 4th Generations

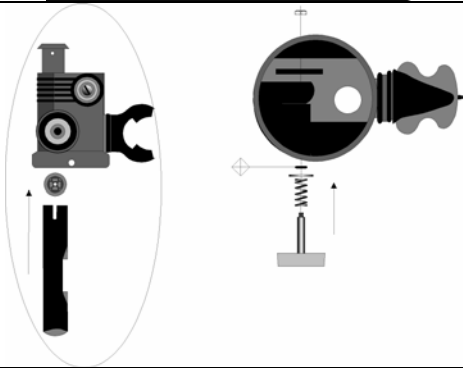
	
<p>Use the Seat Slider tool to position the exhaust seat into the Air 2 body. Insert the exhaust button assembly as shown.</p>	

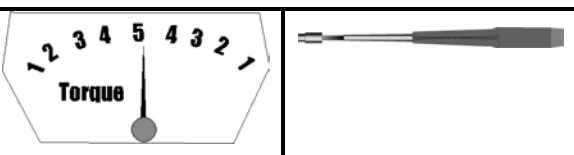
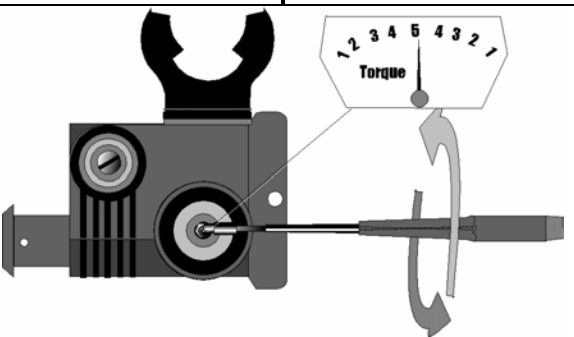
	
<p>Use the 1/4" nut driver to tighten the nyloc nut on the exhaust button stem.</p> <p>Torque to 2.7 in-lbs or 0.3 Newton Meters.</p>	

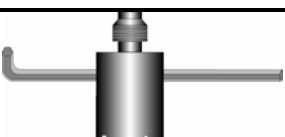
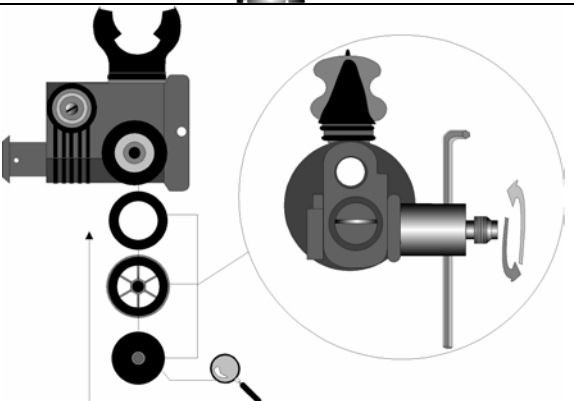
	
<p>Assemble the exhaust valve and spider.</p> <p>Thread into the Air 2 body and lightly tighten using the Air 2 spider tool as shown.</p>	

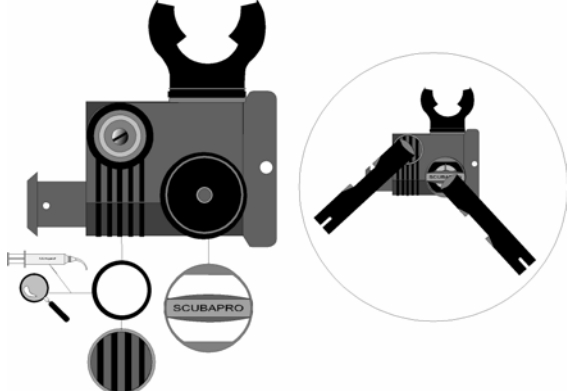

SCUBAPRO AIR2 3rd & 4th Generations

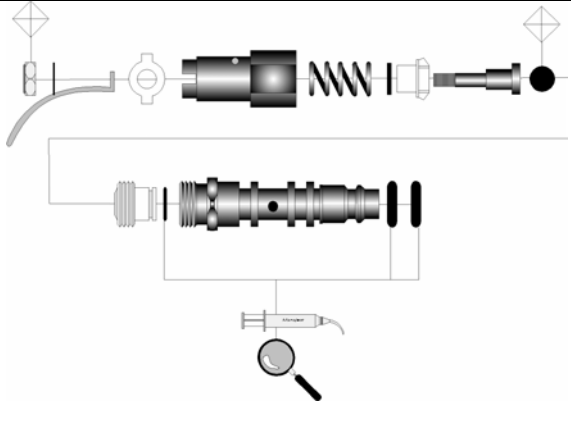
	
<p>Inspect and lubricate the inflator mechanism cover o’ring.</p> <p>Insert the covers for the exhaust and the inflator mechanisms. Lightly tighten using the Seat Slider tool.</p>	

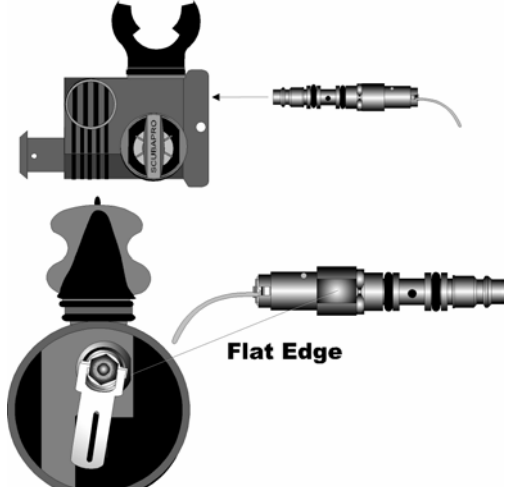
	
<p>Replace the poppet seat. Inspect and lubricate o’rings as shown.</p> <p>Assemble the poppet, orifice, lever and other components of the air barrel. Two threads should show on the seat carrier.</p> <p>CAUTION: Protect the poppet seat to prevent engraving when assembling the air barrel.</p>	

		<p>No tools needed this step</p>
<p>Insert the air barrel assembly into the Air 2 body.</p> <p>NOTE: The flat edge of the air barrel must rest against the flat internal edge of the Air 2 body as shown.</p>	 <p>Flat Edge</p>	

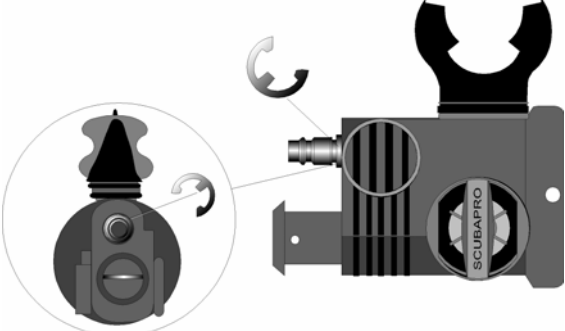

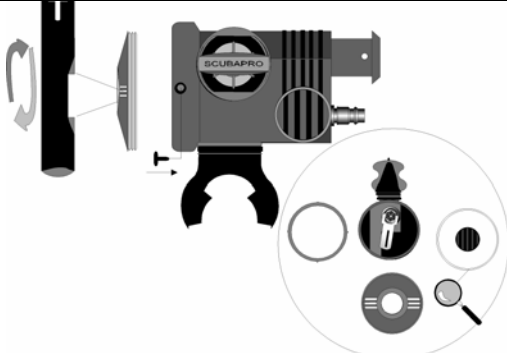
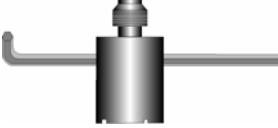
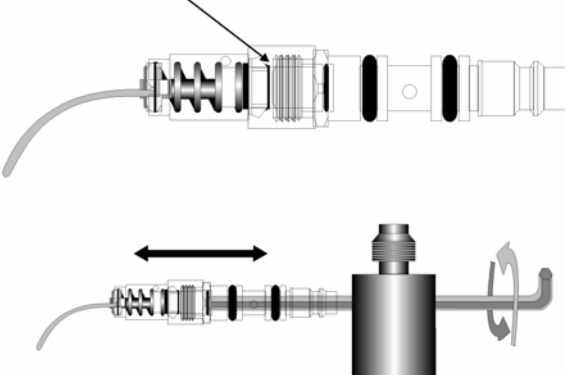
SCUBAPRO AIR2 3rd & 4th Generations

		<p>No tools needed this step</p>
<p>Replace the “c” clip. If needed, use a small screwdriver or flat pick to insure that the “c” clip is tightly in place.</p>		
		
<p>Inspect the diaphragm to insure there are no punctures or wear.</p> <p>Reassemble the diaphragm, friction washer and front cover. Tighten using the Seat Slider tool.</p>		
		
<p>Adjustments are made by inserting the Air 2 spider tool into the quick disconnect side of the air barrel.</p> <p>Turning clockwise reduces the distance between the orifice and the poppet seat and increases the cracking effort.</p> <p>Turning counter-clockwise increases the distance and reduces the cracking effort.</p>		

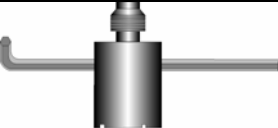
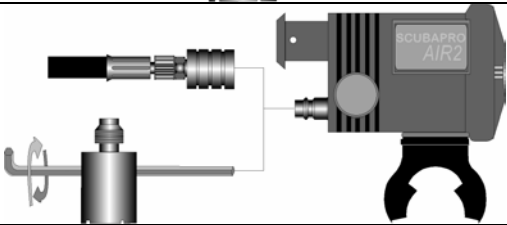
SCUBAPRO AIR2 3rd & 4th Generations

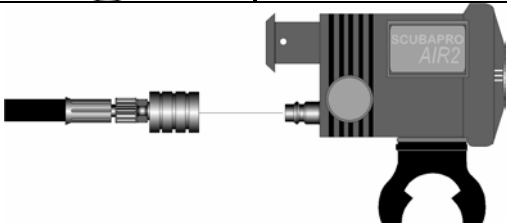
	
<p>Alternate between the Air 2 spider tool and the quick disconnect hose fitting to make final air-on adjustments.</p>	

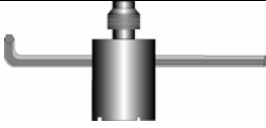
		<p>No tools needed this step</p>
<p>Attach quick disconnect as shown in preparation for testing.</p>		

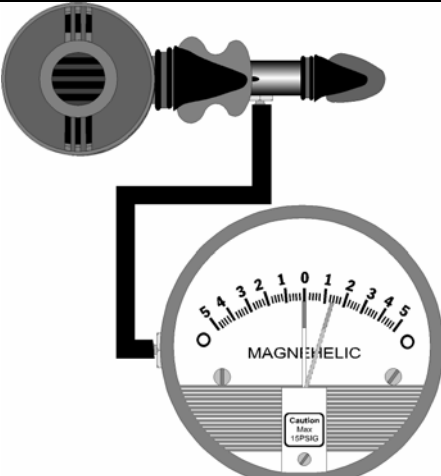
		
<p>Install the Magnehelic gauge as shown. Turn the air on gently.</p> <p>Use the mouthpiece extension and inhale gently, noting the “cracking” effort required to deliver air.</p> <p>Adjust as needed using the Air 2 spider tool.</p> <p>Inhalation range: 1.4 – 2.0 inches of water.</p>		

SCUBAPRO AIR2 3rd & 4th Generations

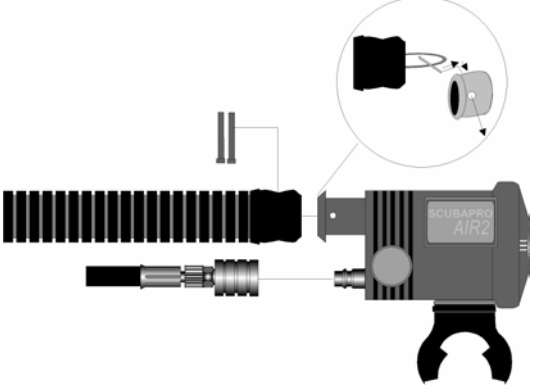
	 A circular icon with a diagonal slash through it. Inside the circle, there is a wrench and a screwdriver. Below the slash, the text "TOOLS NEEDED" is written.	No tools needed this step
<p>Attach quick disconnect and large bore inflator hose. If the BC uses a “pull dump” attached to the inflator hose the mechanism pin must be attached prior to securing the Air 2 to the large bore hose.</p> <p>CAUTION: Be certain that the large bore inflation hose is securely attached to prevent disconnection while in use.</p>	 A technical diagram showing the assembly of a SCUBAPRO AIR2 regulator. The main unit is a grey rectangular device with a black handle and a label that reads "SCUBAPRO AIR2". A large black corrugated inflator hose is being attached to the top of the unit. A small black pin is shown being inserted into a hole on the side of the regulator. A circular inset provides a magnified view of the pin being inserted into the regulator's side hole. Below the main unit, a separate black quick disconnect fitting is shown with a pin inserted into its side.	